

Data for installation and operation

Dimensions

Test space

Cabinet (required space)

1100 mm wide	1385 mm wide
950 mm deep	1850 mm deep
950 mm high	1980 mm high

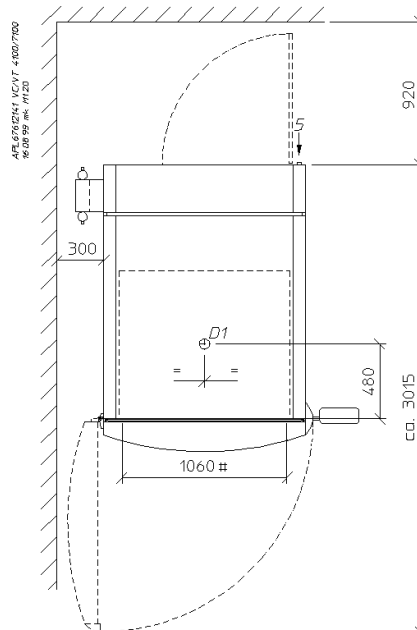
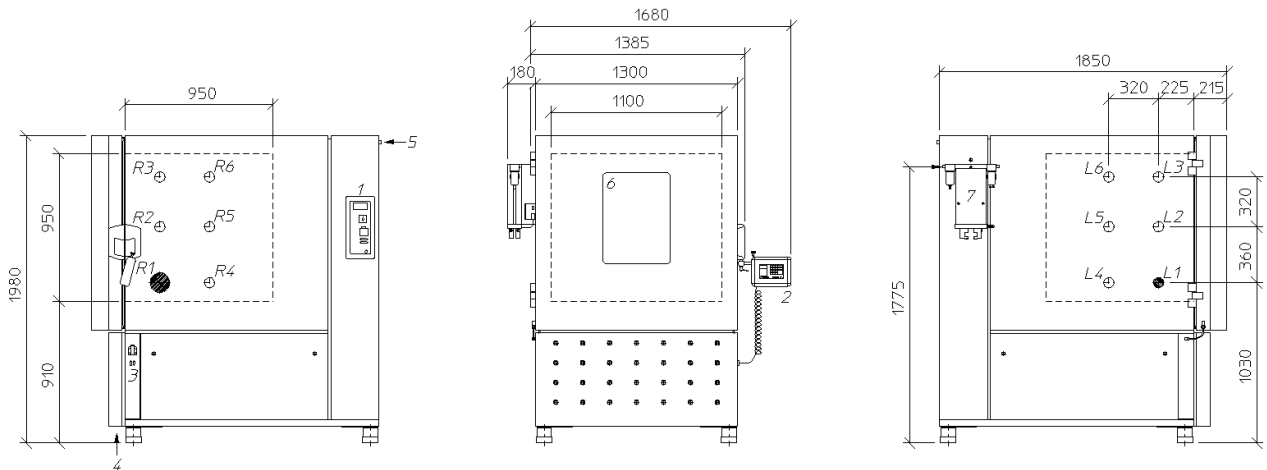

- Entry port installed in basic version
 - R1: NW 125 mm
 - L1: NW 50 mm
 - R2... additional installation positions r.h. side(option)
 - L2.... additional installation positions l.h. side (option)
 - D1 Installation position in the ceiling (option)
- 1) Main switch panel
 - 2) Operator device >touch panel<
 - 3) Connector panel
 - 4) Connection for overflow and condensate drain
 - 5) Electrical connection, cable length approx. 3.5 m
 - 6) Door with window (option)
 - 7) Compressed-air dryer (option)
 - # Distance between shelf supports