

**Data for installation and operation VT 4011 + VT 7011**

Dimensions

Test space

Housing (required space)

560 mm wide  
350 mm deep  
630 mm high

850 mm wide \*  
1030 mm deep  
1640 mm high

\* can be reduced to 800 mm for transport

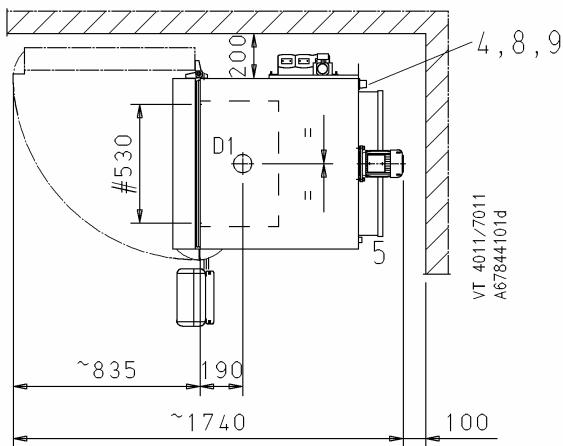
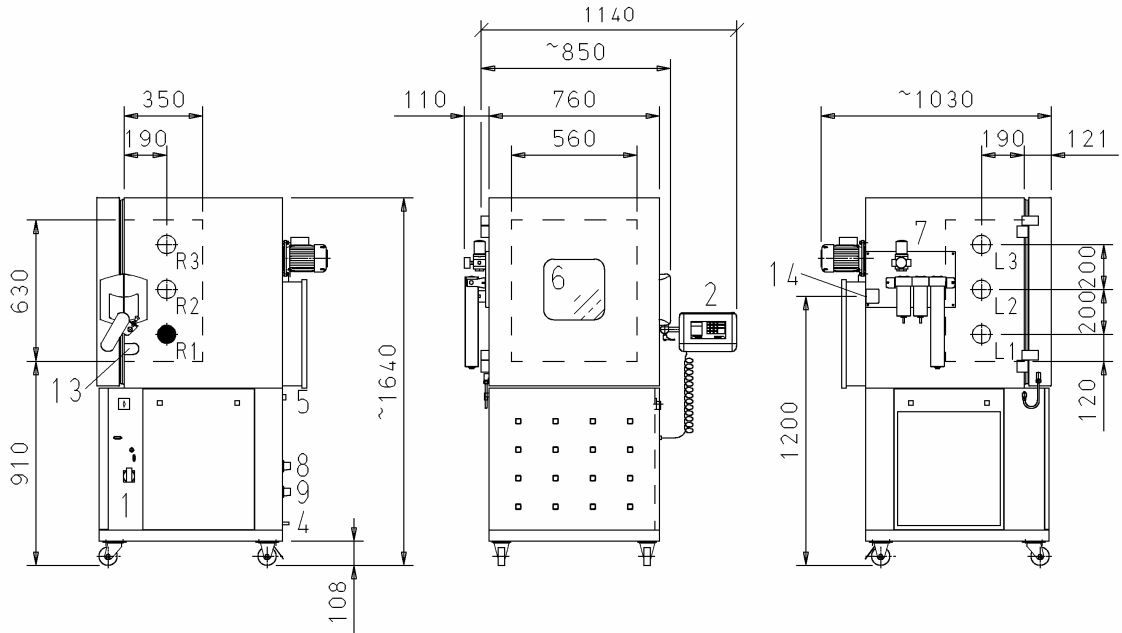

- Entry port installed in basic version
- R1: NW 80 mm
- R2 .... additional installation positions r.h.side (option)
- L1 .... additional installation positions l.h.side (option)
- D1 Installation position in the ceiling (option)
- 1) Main switch panel
- 2) Operator device >touch panel<
- 4) Connection for overflow and condensate drain
- 5) Electrical connection cable length approx. 3,5 m
- 6) Door with window (option)
- 7) Compressed air dryer (option)
- 8) Cooling water outlet (option)
- 9) Cooling water inlet (option)
- # Distance between shelf supports